

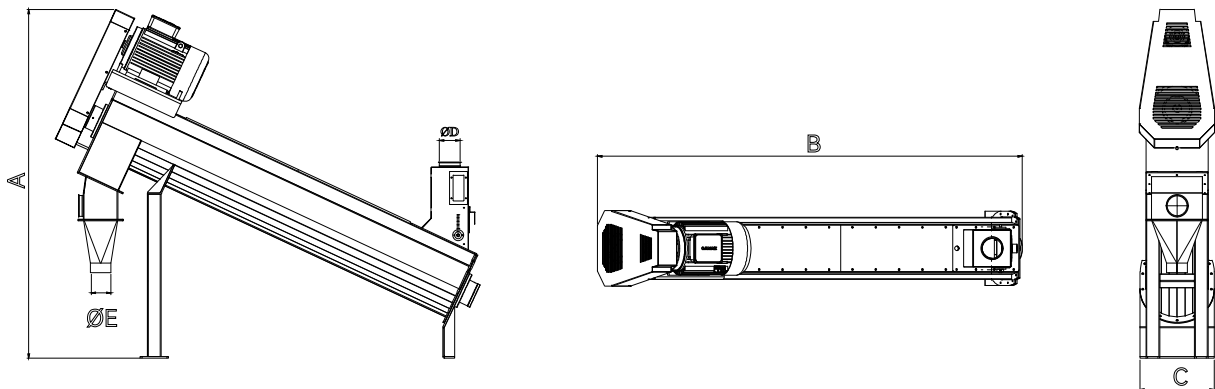

Intensive Dampener

The intensive dampener adds water to wheat in flour mills. Its three-rotor system evenly distributes water, and the 1st and 2nd units anneal wheat for the desired humidity. The chrome nickel parts ensure longevity and health safety. The dampener has high moisture levels, low energy consumption, minimal maintenance, automatic flow rate control, and adjustable moisture rates. It's easy to install and durable for cost.



| Model | Dimension (mm) | | | | | Capacity t/h | Motor kw | Beca Ağırlık kg | Gross Volume m ³ |
|----------|----------------|------|-----|-----|-----|-----------------|-------------|-----------------------|--------------------------------|
| | A | B | C | D | E | | | | |
| TMCT-200 | 1848 | 2434 | 310 | 120 | 120 | 5-7 | 5,5 | 220 | 2 |
| TMCT-357 | 2031 | 2475 | 410 | 120 | 120 | 7-10 | 7,5 | 450 | 2,75 |
| TMCT-511 | 2237 | 2498 | 510 | 150 | 150 | 10-15 | 11 | 500 | 3,75 |
| TMCT-615 | 2667 | 3124 | 610 | 150 | 150 | 15-20 | 15 | 550 | 5,75 |