

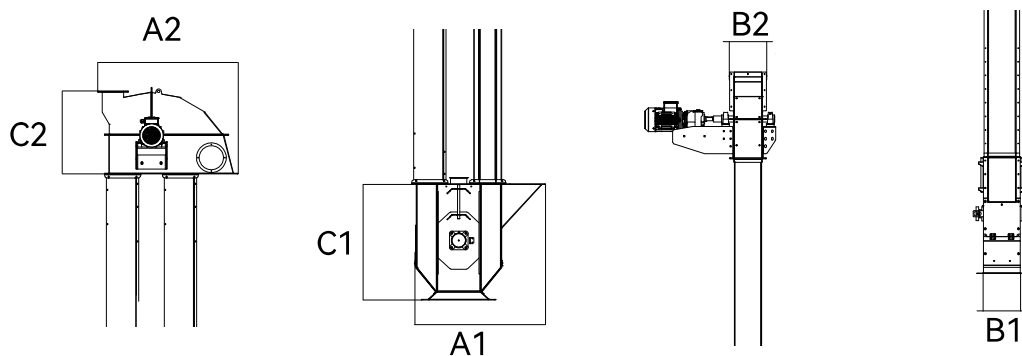

Bucket Elevator

A belted bucket elevator vertically conveys bulk materials or products with a dust-proof design, inspection doors, and elevator head motor base plates that can be dismantled. It can be driven by a chain or belt-pulley driven reducer system, and has a simple montage and de-montage system. The elevator features high efficiency, low power consumption, and smooth operation with minimal maintenance. It also has a movement direction control switch for safety precautions.



Model	Dimension (mm)									Bucket		Speed rpm d/dk	Capacity t/h					
	Product Input			Product Output					Pulley		Model		Pieces per meter	Wheat	Flour	Semolina	Bran	Waste
	A1	B1	C1	A2	B2	C2	D	E	Diameter	Width								
TMKE-358	1084	284	872	1127	230	712	740	260	350	180	140	5	105	9,5	7,5	6,5	4	4,5
TMKE-418	1134	284	922	1177	230	762	790	260	400	180	140	5	100	13	10	9	6	6
TMKE-424	1194	324	978	1283	268	818	790	300	400	240	200	5	100	35	28	24	15	17
TMKE-526	1391	364	1264	1481	308	986	890	320	500	260	220	5	90	52	42	36	22	25
TMKE-628	1546	384	1307	1646	328	1079	990	340	600	280	240	5	80	66	53	45	28	32
TMKE-740	1736	424	1407	1746	368	1179	1090	380	700	400	280	4	80	89	71	61	37	43